

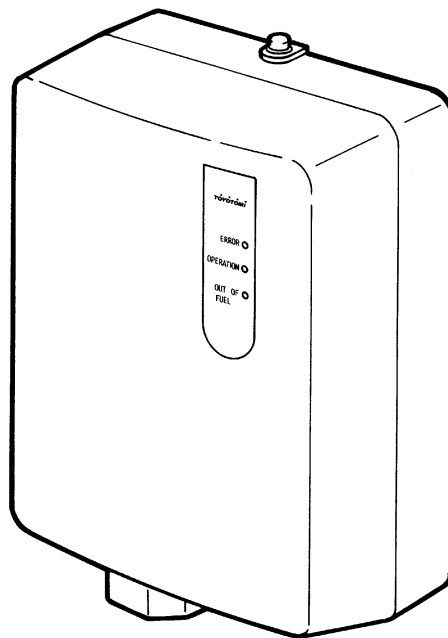

INSTALLATION AND OPERATION INSTRUCTIONS

FUEL LIFTER PUMP

MODEL OPT-91UL



IMPORTANT:

READ AND UNDERSTAND INSTRUCTIONS CAREFULLY BEFORE INSTALLING OR USING LIFTER. RETAIN INSTRUCTIONS FOR FUTURE REFERENCE AND CHECK LOCAL CODES AND ORDINANCES FOR PERMITTED USE.

CONTENTS

PAGE	TITLE
3	SAFETY TIPS
3	Fuel
3	Installation
3	Operation
4	SPECIFICATIONS
4	ELECTRICAL CIRCUIT DIAGRAM
5	COMPONENT PARTS
5	Indication panel
6	SAFETY MECHANISM
6	OPERATION
8	MAINTENANCE
9	STORAGE
10	TROUBLESHOOTING
11	INSTALLATION
11	Unpacking lifter carton
12	Selecting location
12	Safety tips for installation
13	Installation of lifter
15	PIPING
15	Precautions
15	Piping precautions
16	Flaring of pipes
16	Connection of copper pipes
17	Permanent wiring installation
17	Lifting characteristics chart
18	External fuel supply installation kit
19	PARTS LIST

SAFETY TIPS

Before operating your lifter pump, please review these safety tips.

FUEL

WARNING: Never use any fuel other than clear or red dyed ASTM D3699 1-K Kerosene or ASTM D396 No.1 or No.2 Fuel Oil. **NEVER USE GASOLINE** or other flammable liquid! Use of gasoline can cause a fire.

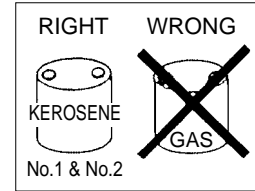

INSTALLATION

Note : This lifter pump must be installed in accordance with National Fire Protection Association Code NFPA 31.

This lifter is for indoor installation only. Electrical components are not waterproof. Also, when used in a cold area, condensation may occur inside the lifter, possibly causing problems. To avoid such trouble, it is recommended not to install the lifter outdoors or on cool area.

The lifter must be installed in accordance with the National Electrical Code (NFPA 70) and all other codes that are applicable to the local jurisdiction.

IMPORTANT

This lifter is designed and tested for use with Oil Miser, Toyostove and Toyotomi products.

OPERATION

1. The maximum lifting height is 26 feet (8 m). (Fig. 1)
2. The height (A) between the lifter and the heater should be the height specified for the heating appliance. (16 in. Min., 8 ft.Max.) (Fig. 1)
3. Never close the main tank valve while heater is in use. If the valve is closed during the lifter operation, it may cause a pump lock, etc. (Fig. 1)
4. To prevent air locks in fuel pipe, fuel line should be smooth with no U-shaped or sharp bends. (Fig. 1)
5. Never use the lifter for the purpose other than supplying fuel to the heaters.
6. This lifter is intended to refuel the heater by means of gravity pressure difference; therefore, it cannot be used for a heater which do not have an oil level control such as oil leveller or solenoid valve.
In the event that the lifter is connected to the sub fuel tank of a wick fed type heater by mistake, it will cause an overflow of the fuel on the heater. (Fig. 2)

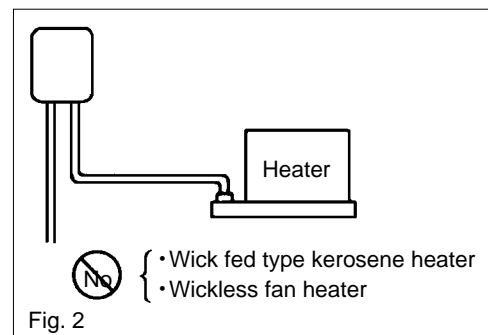
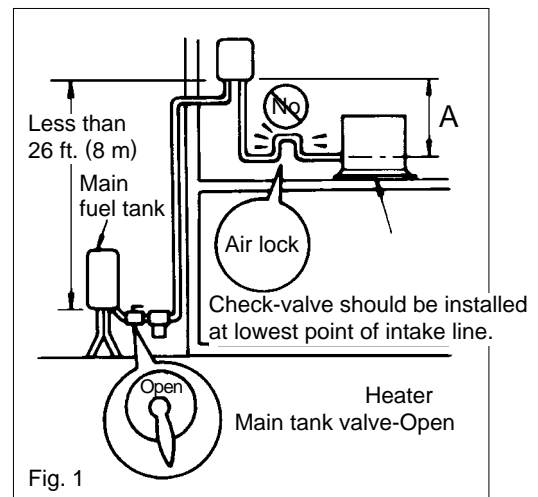

SPECIFICATIONS

PUMP TYPE	Suction (Head or fall type)
LIFTING HEIGHT (MAX.)	26 ft. (8 m)
MAXIMUM HORIZONTAL DISTANCE	131 ft.
OUTLET FLOW RATING	4 gal./h (15 L/H) at 20 ft. (6 m)
INLET PIPE SIZE	3/8" O.D.
POWER SUPPLY	AC 115V, 60Hz
POWER CONSUMPTION	16W
SUMP TANK CAPACITY	0.24 gal. (0.9 L)
DIMENSIONS	Width: 8" (202 mm) Depth: 4-1/4" (107.5 mm) Height: 10-7/8" (278 mm)
WEIGHT	7.1lbs. (3.2 kg)
FUEL TYPE	ASTM D3699 1-K Kerosene or ASTM D396 No.1 or No.2 Fuel Oil

ELECTRICAL CIRCUIT DIAGRAM

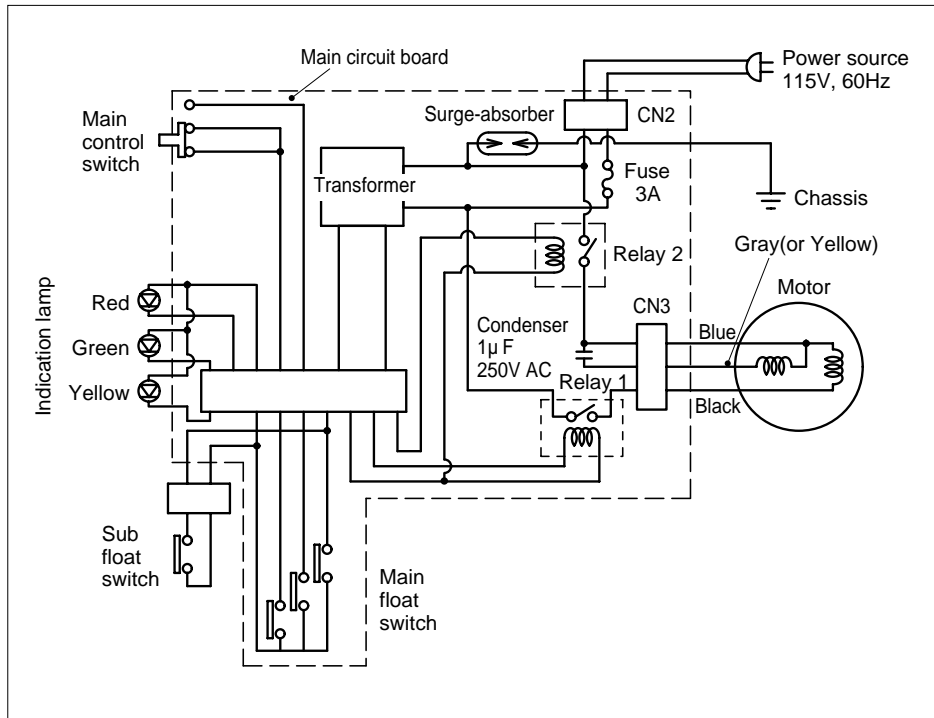

COMPONENT PARTS

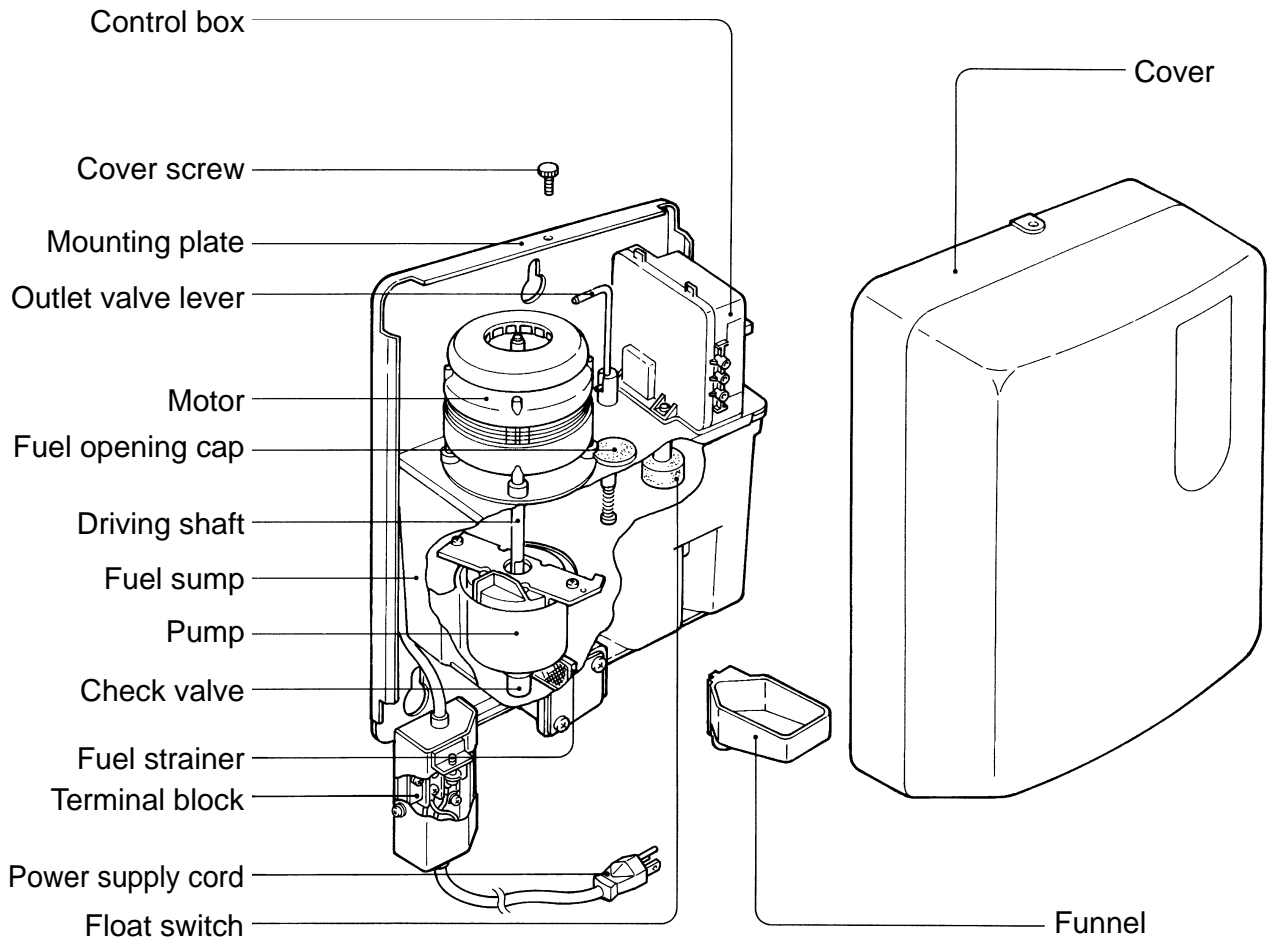

INDICATION PANEL

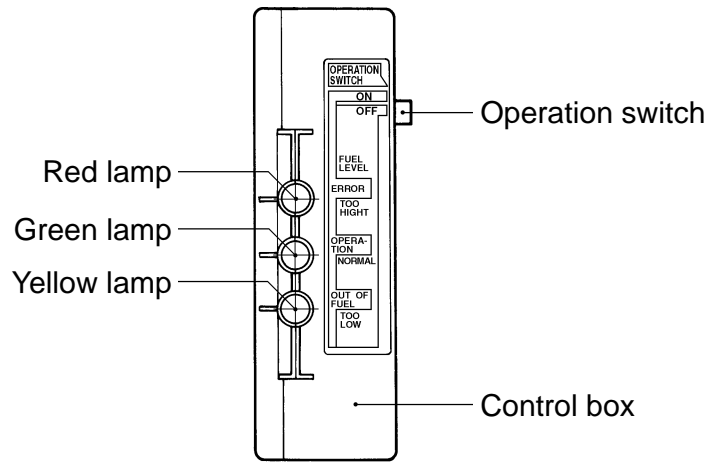

SAFETY MECHANISM

1. Overflow Prevention

- (a) If the lifter is tilted while in operation, the red lamp comes on and the operation stops.
- (b) If an electric part is in malfunction and the oil level exceeds the normal oil level, the red lamp comes on and the operation stops.

2. Idle Operation Prevention

If the fuel sump is empty while in operation or if the lifter does not pump up the fuel because of a pump malfunction, etc., for more than 20 minutes the yellow lamp comes on and the motor stops.

3. Continuous Operation Prevention

If the lifter is operated over for 30 minutes due to motor lock, all lamps will flash and the operation is stopped.

OPERATION

When Operating Lifter For The First Time After Installation:

Before operating the lifter in the following procedure, check if installation and piping are performed in the manner as described in "INSTALLATION" (Page 11~13) and "PIPING" (Page 15~17).

1. Remove the cover screw at the upper side of the cover and remove the cover bringing it slightly forward.
2. Set the outlet valve lever to CLOSE by pulling up and rotating the lever, turn the operation switch to OFF position (Fig. 3), and put the power supply cord into the electrical outlet. The yellow lamp will flash to indicate insufficient oil in the fuel sump.
3. Pour about 0.12 gallons (450 cc) of fuel into the fuel opening by using the attached funnel. When the fuel sump is filled sufficiently, the green lamp will flash to indicate the normal oil level. (Fig. 3)

CAUTION: Use clear or red colored kerosene or No.1 or No.2 Fuel Oil only!
Be sure there is no contamination such as dirt, water or other particles.

Note: If an excessive amount of fuel is filled, the red lamp will flash to indicate excessive oil level. In this case, set the outlet valve lever to OPEN and supply fuel to the heater until it reaches normal oil level. (Fig. 3)

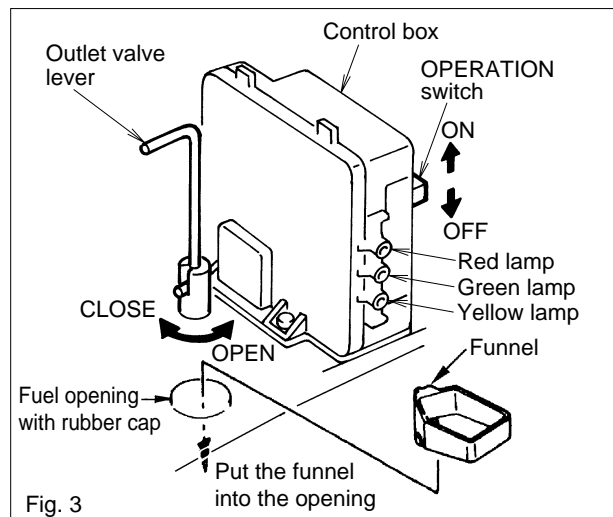

4. Turn the operation switch to ON position. The green lamp will change from flashing to continuous and the motor will start operating.

CAUTION: Do not touch the motor fan. The motor fan will start at the same time when turning the operation switch to ON position.

Note: When first started, the intake line contains air and a muted "THUMPING" sound will be heard. Once the line is filled with fuel the sound will cease.

Note: If this does not stop until just before the motor stops, air is leaking into the pipe. Check the pipe and all connections, especially the flares.

Note: If the lifter is installed correctly, a proper amount of fuel will be pumped up in about 5 to 12 minutes at which time the motor will stop.

5. Turn the outlet valve lever to OPEN.

CAUTION: Be careful not to touch the motor fan when rotating the outlet valve lever.

(a) If the outlet pipe is longer than 33 ft. (10 m), turn the outlet valve lever to OPEN and CLOSE repeatedly several times. When the motor starts, set the outlet valve lever to CLOSE, and when the motor stops, set it to OPEN. (Fig. 4)

(b) Before turning the outlet valve lever to OPEN, quickly repeat the procedure of holding up the lever fully and turning it to CLOSE four or five times. To prevent air lock which may occur in the pipe.

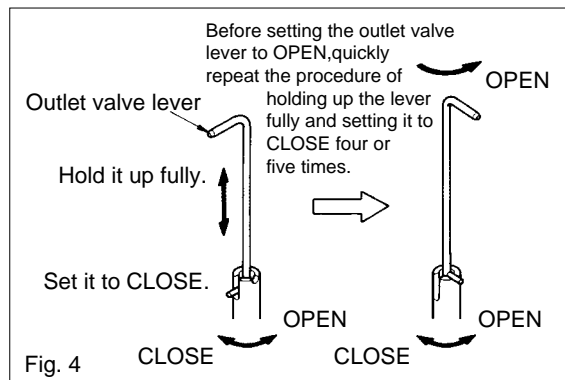

(c) Be sure that fuel is not leaking from any part of the lifter as well as from the inlet/outlet pipes and all joints.

6. Remove the funnel from the fuel opening, and then store it in place.

7. Plug the hole of the fuel opening securely with the rubber cap.

8. Replace the cover and attach with cover screw. At this point, the lifter is ready to perform automatic operation to supply fuel to the heater.

When Restarting The Lifter In The Next Season:

1. Remove the cover screw and remove the cover.

2. Turn the outlet valve lever to CLOSE, turn the operation switch to OFF, and put the power supply cord into the electrical outlet.

3. Turn the operation switch to ON.

Note: If the red lamp comes on or flashes when the operation switch is OFF position, the motor does not rotate when turning the operation switch to ON.

Note: If the yellow lamp or green lamp flashes when the operation switch is OFF position, the green lamp will flash and the motor will start rotating to perform lifting for about 5 to 12 minutes when turning the operation switch to ON. (Fig. 5)

4. Turn the outlet valve lever to OPEN to supply fuel to heater.
5. Replace the cover and attach it with the cover screws securely.

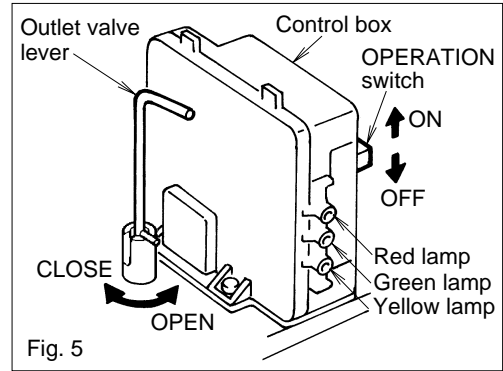

MAINTENANCE

CAUTION: Be sure to turn the operation switch to OFF and disconnect the power supply cord from the electrical outlet before performing any checks or cleaning.

Note: Accumulated dust and water may cause problems. Check and clean the lifter before using it.

1. Cleaning
Remove the cover and remove any dust from around the motor.

2. Clean fuel strainer
If the fuel strainer is clogged, clean it in the following procedure.

- (a) To catch the fuel which will drain out, set a rag or folded paper towel below the strainer cover. (Fig. 6)
- (b) Loosen the two (2) screws from the strainer cover and remove. (Fig. 6)
- (c) Remove the fuel strainer and rinse with clean fuel. (Fig. 7)
- (d) Return the fuel strainer to its original position. Replace the strainer cover and replace screws.
- (e) Wipe away any spilled fuel.
- (f) Be sure to confirm that there is no fuel leakage from the strainer cover.

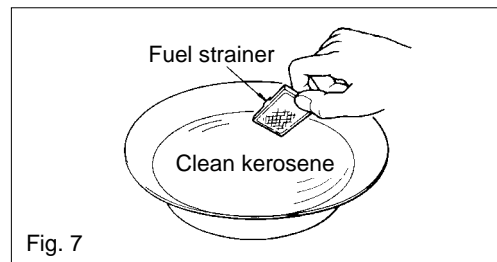
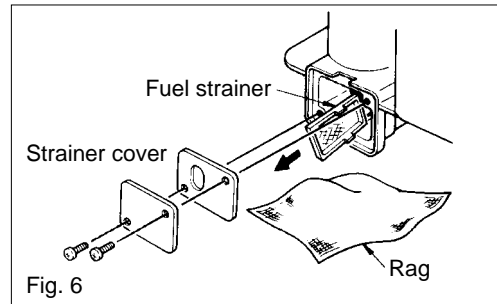

3. Draining from fuel sump
Water can collect in the fuel sump. Drain any water from the fuel sump prior to each season's start up.

- (a) Remove the two (2) drain screws at the bottom of the unit. (Fig. 8)

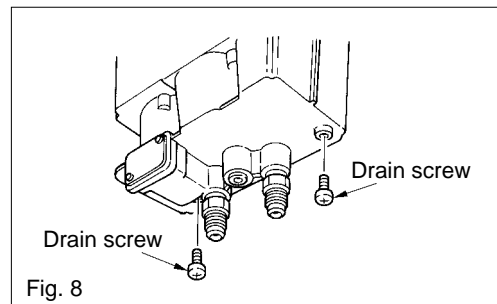

Note: To catch the fuel and water that will drain out, set a half gallon container under the unit.

- (b) Water and fuel will be discharged together.
- (c) Tighten the two (2) drain screws.
- (d) Operate the lifter for a while to confirm that no fuel is leaking from the drain screws.

STORAGE

At the end of each heating season, or when you do not plan to use the lifter for an extended period, the following procedures are recommended.

1. Turn the operation switch to OFF position.
2. Unplug the lifter.
3. Turn the outlet valve lever to CLOSE.

TROUBLESHOOTING

Sympton	Cause	Solution
Red lamp ON.	<ul style="list-style-type: none"> - Too much fuel put in fuel sump. - Lifter tilted by mistake. - Upper limit float switch defective. - Control box malfunction. 	<ul style="list-style-type: none"> - Let oil level go down, then turn it ON. - Correct tilt. Turn operation switch to OFF, then turn it ON. - Replace float switch. - Check fuse then replace the circuit board.
Motor does not rotate.	<ul style="list-style-type: none"> - Too much fuel in fuel sump. - No power supplied. - Pump and/or motor lock. - Control box malfunction. 	<ul style="list-style-type: none"> - Let oil level go down, then turn it ON. - Check power supply and operation switch. - Replace pump and/or motor. - Replace the circuit board.
Motor turns, but no fuel pumped up.	<ul style="list-style-type: none"> - Insufficient fuel in fuel sump for priming. - Pump height too high. - Main fuel tank empty. - Main tank valve closed. - Air leak from inlet pipe. - Driving shaft is off or broken. - Pump valve lock. 	<ul style="list-style-type: none"> - Add priming fuel as instructed. - Reduce pump height to 26 ft. (8 m) or less. - Fill the main fuel tank. - Open the valve. - Repair leaks and check all joints and connections. - Fix or replace the shaft. - Replace the pump.
Fuel pumped up, but no fuel fed to heater.	<ul style="list-style-type: none"> - Outlet valve closed. - Outlet pipe air lock. - Outlet pipe clogged. 	<ul style="list-style-type: none"> - Open outlet valve. - Purge air from pipes. - Clean the clogged pipe.
All lamps go off.	<ul style="list-style-type: none"> - No power supplied. - Control box malfunction. 	<ul style="list-style-type: none"> - Check power supply and turn the operation switch to ON. - Check fuse on board and/or replace circuit board.
Yellow lamp ON.	<ul style="list-style-type: none"> - Fuel consumption larger than lifter can pump up. - Inlet pipe clogged. - Air leak from inlet pipe. - Fuel strainer clogged. - Fuel leak from outlet pipe. - Driving shaft is off or broken. - Pump and/or motor lock. - Pump valve lock. 	<ul style="list-style-type: none"> - Consumption is too much for lifter pump add another lifter pump. - Clean the clogged pipe. - Repair leaks. Check and tighten fittings. - Clean the strainer. - Repair the leaks. - Fix and replace the shaft. - Replace the motor and pump. - Replace the pump.

Green lamp ON.	<ul style="list-style-type: none"> - Lower limit float switch defective. - Pump and/or motor lock. - Pump valve lock. 	<ul style="list-style-type: none"> - Replace float switch. - Replace pump and/or motor. - Replace the pump.
All lamps flash.	<ul style="list-style-type: none"> - Fuel consumption larger than lifter can pump up. - Inlet pipe clogged. - Driving shaft is off or broken. - Control box malfunction. 	<ul style="list-style-type: none"> - Consumption is too much for lifter pump add another lifter pump. - Check the clogged pipe. - Fix or replace shaft. - Replace the circuit board.
Fuel sump emptied when power kept turned OFF.	<ul style="list-style-type: none"> - Fuel leak from outlet pipe. - Oil level down because of fuel consumption while lifter was off. - Fuel leak from check-valve. 	<ul style="list-style-type: none"> - Repair the leaks. Check all joints and connections. - Turn lifter on. - Replace the pump.
Loud noise while in operation	<ul style="list-style-type: none"> - Pump height too high. - Air leak from inlet pipe. 	<ul style="list-style-type: none"> - Reduce pump height to 26 ft. (8 m) or less. - Repair the leaks. Be sure check-valve is in place.

INSTALLATION

UNPACKING LIFTER CARTON

1. Take the lifter out of the shipping carton.
2. Remove the tape, bags, packing materials from the lifter body.
3. Check the following accessories before installing. (Fig. 9)

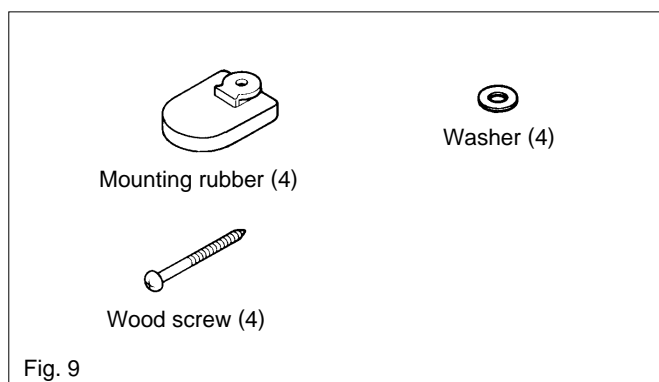

SELECTING LOCATION

CAUTION: This lifter is for indoor use only. Check local codes and ordinances for permitted uses.

1. Select a safe and solid place to install the lifter.
2. Select a place easy to inspect and maintain.
3. Select a location away from direct sunlight and heat sources.
4. Maintain the shortest piping possible by selecting a location as close as possible to the main fuel tank. If the piping to the main fuel tank is long, a properly located check-valve will eliminate a long wait for fuel delivery.

SAFETY TIPS FOR INSTALLATION

Follow the safety tips below when installing the lifter.

1. Adjust the height of the lifter as follows.
 - (a) Height between the main fuel tank valve and the bottom of the lifter:
26 ft. (8 m) maximum
 - (b) Height between the floor level of the heater and the bottom of the lifter:
8-1/2 ft. (2.5 m) maximum or a pressure reducing valve is required.
 - (c) At least 16 in. higher than heater fuel intake.
2. Max. length of the pipe between the main fuel tank and the lifter:
131 ft. (40 m)
More than 50 ft. (15 m), 1/2 in. line is recommended instead of 3/8" tubing.
3. If one lifter is used to fuel several heaters, then allow about 1/3 of total flow to be lost to internal resistance. If several heaters are to be used, preferably install the lifter at a midway point among those heaters.

IMPORTANT

This lifter is designed for use with Oil Miser, Toyostove and Toyoyomi products.

4. If a fuel line is run to one heater on the first floor from the main fuel tank by means of natural gravity and another heater on the second floor by the use of this lifter, then the branch point of the pipes for these two heaters should be located close to the outlet of the main fuel tank. Set the "head"(A) between the lifter and the heater within the height specified for the heating appliance. (16 in. Min., 8 ft.Max.) (Fig. 10)

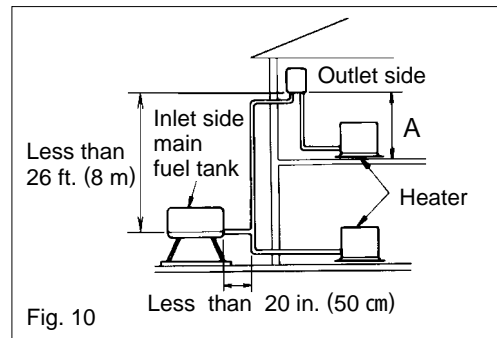

5. Refueling by series operating lifters:
 (a) This lifter is capable of pumping a maximum head of 26 ft. (8 m) at maximum, by using more than two units a higher height can be obtain in series.

Note: In case of operating the lifters connected in series. install them in such a manner that the upper unit has an approximately 3-1/3 ft. (1 m) greater head for both vertical and horizontal directions than the lower unit. (Fig. 11)

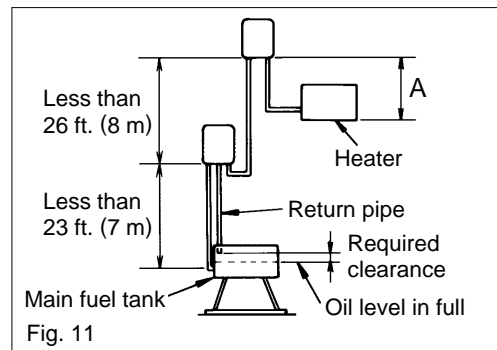

(b) Be sure to install a return pipe for operating with series-connected lifters. Install the return pipe in such a manner that there will be a clearance provided between the outlet of the return pipe and the full oil level line in the main fuel tank. (Fig. 11)

*If oil meters are installed then the number of the oil meters which are connected on the outlet side shall be less than three units. It should be noted that the air remaining inside the oil meter may expand by the change of surrounding temperature, possibly causing the fuel to flow back to the lifter. (Fig. 12)

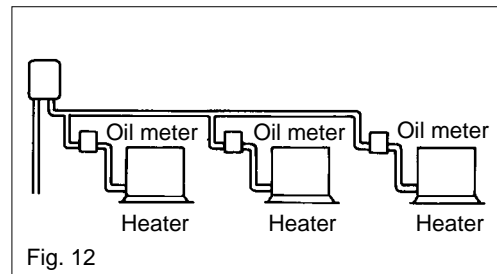

CAUTION: Sufficient care should also be taken when installing more than four oil meters, which may jeopardize the lifter to overfill and leak oil.

INSTALLATION OF LIFTER

1. Check the accessories before installing.

Mounting rubber (3)
 Washer (3)

Wood screw (3)

2. Make four (4) small holes on the wall as per the mounting dimension diagram. (Fig. 13)

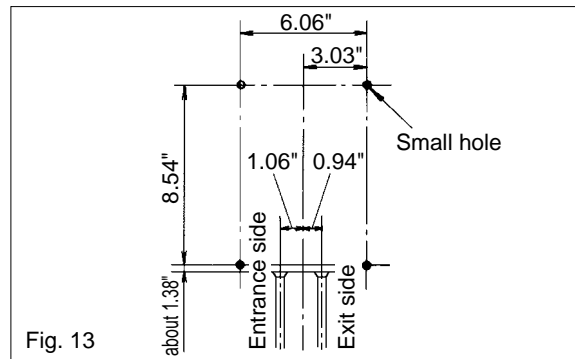

3. Fix the four (4) mounting rubbers to the wall by using the wood screws and the washers. In this case, do not tighten the mounting rubbers excessively. (Fig. 14)

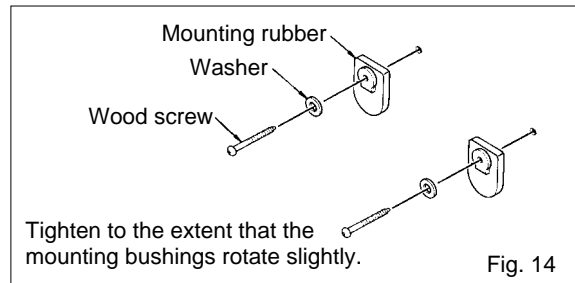

4. Install the mounting plate over the mounting rubbers using the holes. Slide the mounting plate down. (Fig. A,B)

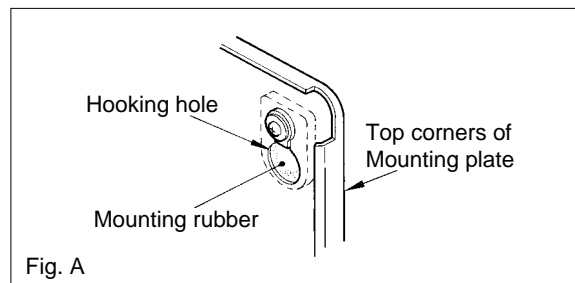

5. Tighten the four (4) screws securely. Be sure not to touch the motor's cooling fan or the control box with the screwdriver.

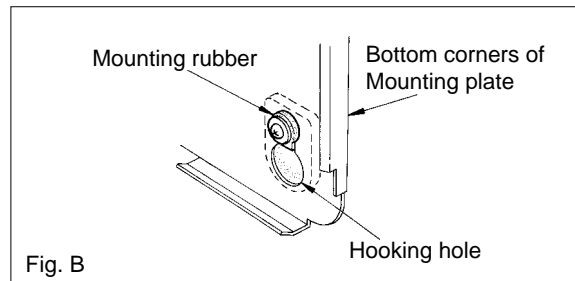

PIPING

PRECAUTIONS

1. Use 3/8 in. (9.53 mm) in outside diameter and not less than 0.032 in. (0.8 mm) thickness copper tubing.

Note: The copper tubing may not be accepted by local building inspection authorities. Check local codes and ordinances for permitted use. In these instances, the piping may need to be made of wrought iron or steel. (Fig. 15)

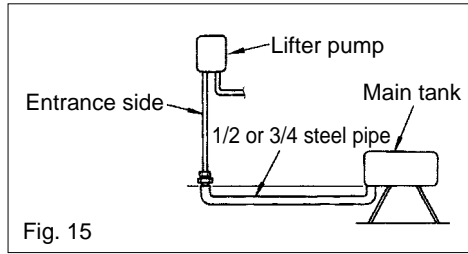

2. When cutting the copper pipe, be sure to use a tubing cutter and remove burrs from the cut surface completely.
3. Be sure to bend the copper pipe before connecting it.

PIPING PRECAUTIONS

1. Install the horizontal pipe on the inlet side as low as possible to the point which is the closest to the lifter and from which the vertical pipe rises straight up to the lifter. (Fig. 16)
This will reduce suction stress on the lifter pump.

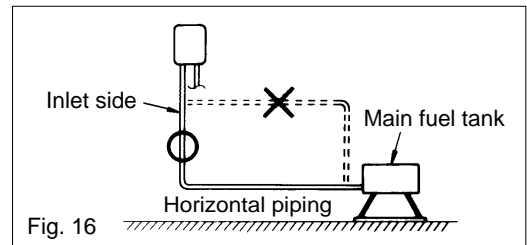

- (a) In case of installing a multiple number of the lifters with one main fuel tank, install a large diameter horizontal piping in a lower level than the baseline of the main fuel tank, from where the branch vertical pipes are to be connected to their respective lifters. (Fig. 17)

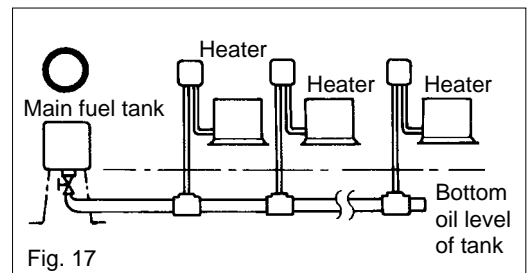

(b) The large diameter horizontal piping should not be installed at a higher level than the bottom of the fuel tank. As it will cause the pumps to overload and require excessive time for suction or the lifter to be incapable of suction. (Fig. 18)

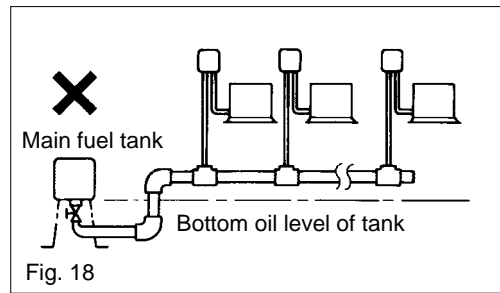

2. The amount fuel remaining inside the outlet line must be less than 1.3 gallons (5 liters).

Note: If too much fuel is in outlet lines then it may expand with high ambient temperature, subsequently flowing back and out of the lifter.

3. When inspecting the lines and joints for leakage, care must be taken not to cause any pressure rise inside the pipings. Such pressure may cause the lifter to malfunction.

FLARING OF PIPES

1. Install the flare nut provided onto the copper tube.
2. Flare the pipe by using a good flaring tool.
Note: Be sure flare is "CLEAN".
3. Push flared pipes against the joint nut and tighten the flare nut.
Fasten nut securely, but do not overtighten.

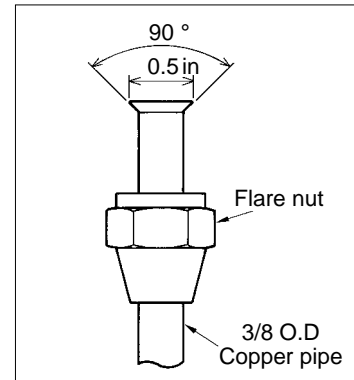

CONNECTION OF COPPER PIPES

1. When connecting a copper pipe to the main fuel tank without a drain, raise the inlet pipe 2 in. (5 cm) or more above the bottom of the tank (so that it does not take-up water or sediment).
2. When connecting a copper pipe to the lifter, use the following procedure:
 - (a) Cut the copper pipe to size and slip the flare nut onto pipe.
 - (b) Flare the pipe by using a good flaring tool. Push flared pipe against the joint nut fitting and tighten nut with the torque approx. 220 lbs-in. by a double wrench.

CAUTION: Flush line briefly with kerosene before connecting to pump and make sure that fuel line is free from any particles or copper cuttings.

PERMANENT WIRING INSTALLATION

WARNING: Make sure power supply cord is disconnected to avoid any electric shock before servicing. Electric shock may cause serious injury. It is recommended that installation be conducted by a licensed electrician.

1. Remove two (2) screws and junction box cover.
2. Disconnect ground wire and two power supply cords.
3. Squeeze strain relief bushing with adjustable pliers to remove plastic bushing from the power supply cord bracket. Remove the power supply cord.
4. Insert the power supply cable from junction box and connect ground wire to the base and power wires to the terminal.
5. Replace junction box cover and secure the cover with two (2) screws.

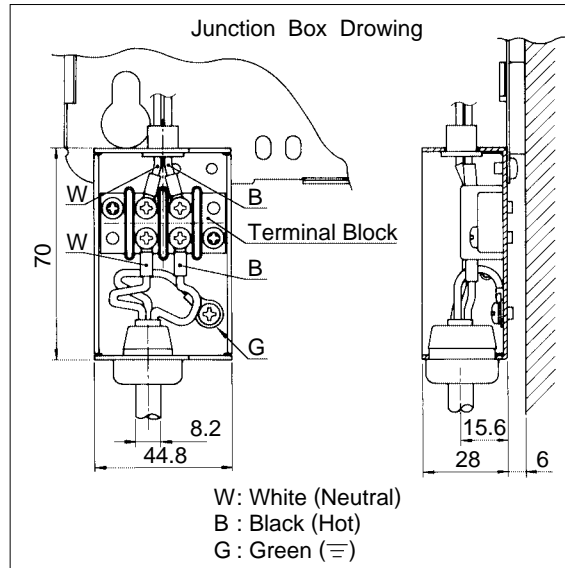

LIFTING CHARACTERISTICS CHART

Use this chart to locate the lifter pump properly. Calculate the fuel flow volume by 1/3 of the output capacity from the chart including surplus.

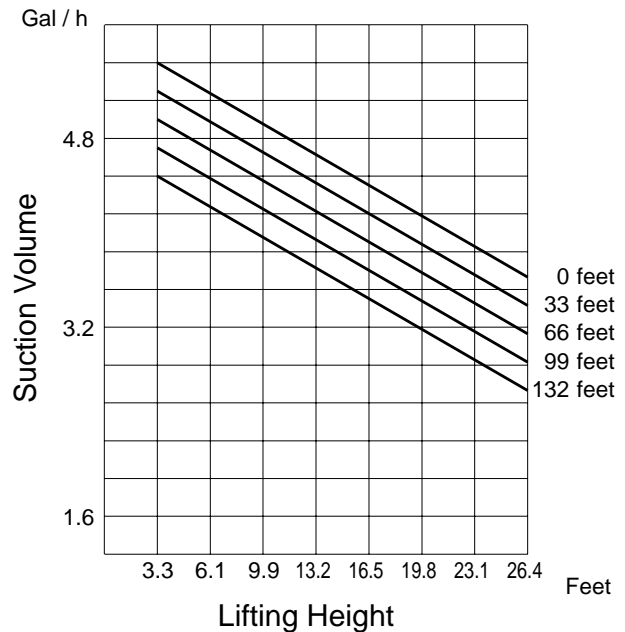

Note: The lifting pipe is a 3/8" OD copper pipe.

EXTERNAL FUEL SUPPLY INSTALLATION KIT (OPTION)

PART # 10005098

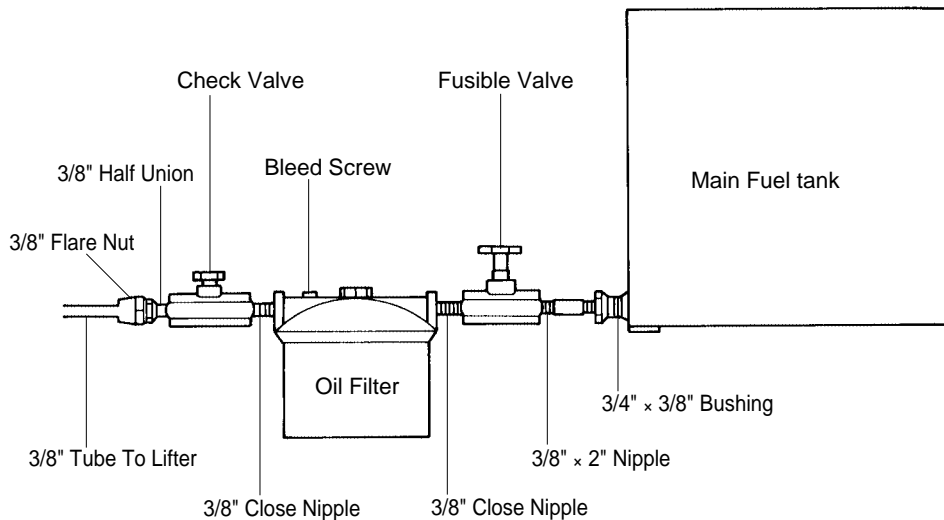

KIT CONTENTS:

- 2 3/8 fusible link valves
- 1 3/8 check valve
- 1 3/4 x 3/8 bushing
- 1 3/8 x 2 galvanized nipple
- 1 3/8 galvanized close nipple
- 3 3/8 x 3/8 brass flare half union adaptors
- 3 3/8 flare nuts
- 1 3/8 x 3/8 union
- 1 oil filter

NOTE : EXTERNAL TANK INSTALLATIONS MUST COMPLY WITH THE NATIONAL FIRE PROTECTION ASSOCIATION CODE NFPA 31, OR LOCALLY APPLICABLE CODES SUCH AS THE 1979 UNIFORM MECHANICAL CODE No. 5-1 THAT ARE CONSISTENT WITH NFPA 31. CHECK WITH YOUR LOCAL BUILDING OFFICIAL AND USE A QUALIFIED INSTALLER.

KIT IS NOT PART OF UL LISTED DEVICE.

PARTS LIST

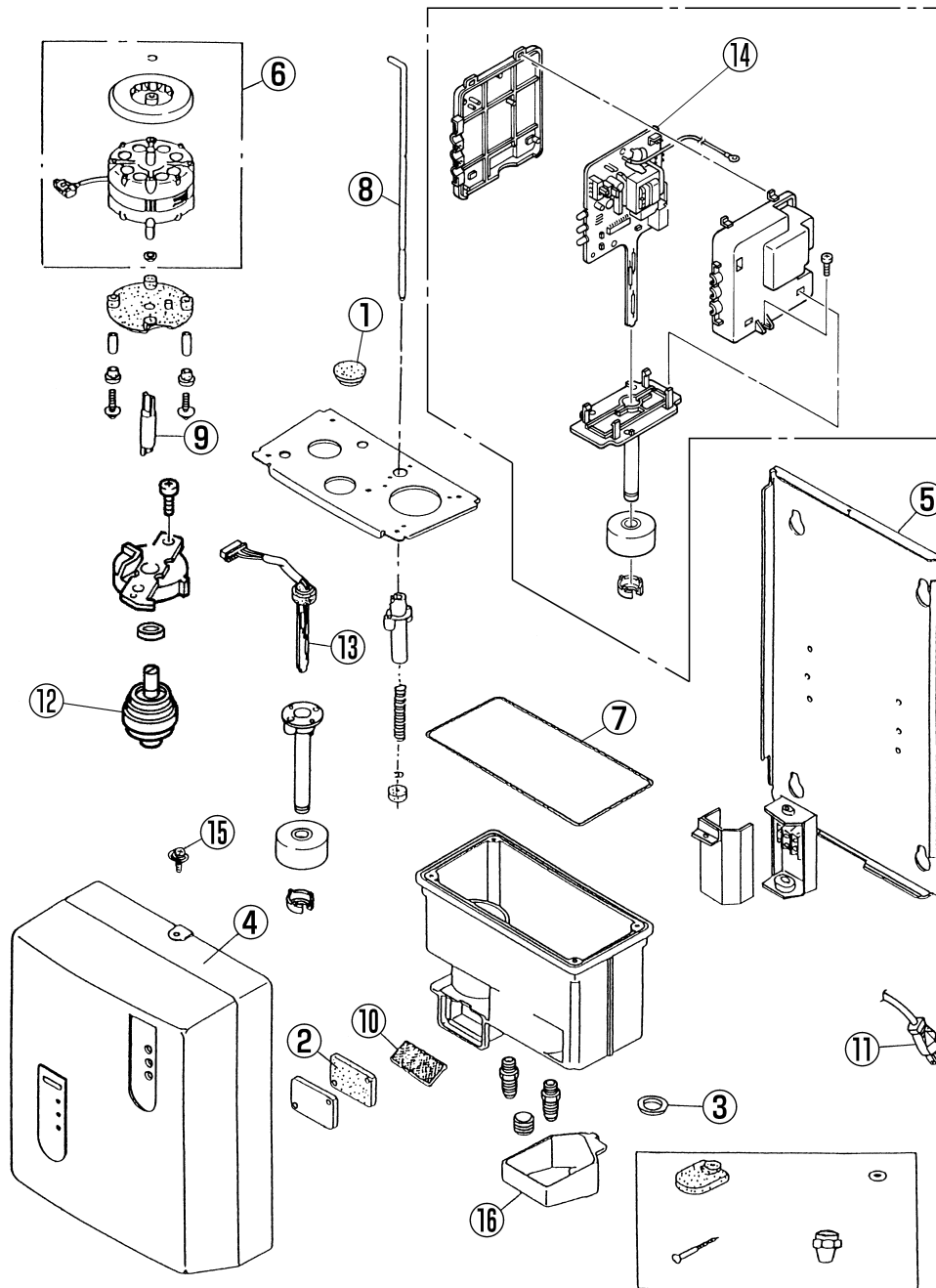

REF#	PART#	PART NAME	REF#	PART#	PART NAME
1	20459824	Fuel opening cap	9	20459882	Drive shaft
2	20459852	Strainer gasket	10	20459850	Fuel strainer
3	20459880	Drain packing	11	20475535	Power supply cord
4	20477546	Cover	12	20459819	Pump assembly
5	20459829	Mounting plate	13	20477576	Switch circuit
6	20459837	Motor assembly	14	20477512	Main circuit board
7	20459815	O-ring(S150)	15	20459805	Cover screw
8	20459817	Outlet valve lever	16	20459825	Funnel

LIMITED WARRANTY

TOYOTOMI U.S.A., INC. ("TOYOTOMI") warrants each product and any parts thereof sold by it to be free from defects in materials or workmanship under normal use and service for TWELVE (12) MONTHS from the date of delivery to the original purchaser at retail subject to the following terms and conditions:

WHAT IS COVERED: Product or any parts thereof which are defective in materials or workmanship.

WHAT IS NOT COVERED:

(1) This warranty does not extend to any defect due to the negligence of others; failure to install, operate or maintain unit in accordance with installation instructions (operating and maintenance instructions are furnished with each new unit); unreasonable use; accidents; alteration, use of unauthorized or non-standardized Toyotomi parts and accessories; electrical malfunction, i.e., as resulting from power surges, short circuit, etc.; incorrect installation; use of any fuel other than that specified in owners manuals; or repair by anyone other than a service facility specified by Toyotomi.

(2) Normal wear and tear of parts, including accessories.

(3) This warranty does not cover shipping costs.

(4) Use with products not manufactured by Toyotomi.

WHO IS COVERED: The original purchaser at retail.

WHAT WE WILL DO: TOYOTOMI will either repair or replace, at its option, all defective parts free of charge that are covered by this limited warranty on a carry-in basis, to your nearest authorized dealer or distributor of TOYOTOMI.

WHAT YOU MUST DO FOR WARRANTY SERVICE: You must return the defective Product or part to any authorized dealer or distributor of TOYOTOMI with this LIMITED WARRANTY and a copy of your bill of sale or credit card charge receipt or other document evidencing the date of the Product's delivery. If service is not available locally, please contact our CUSTOMER RELATIONS DEPARTMENT at:

TOYOTOMI U.S.A., INC.
604 Federal Road, Brookfield, CT 06804
(203) 775-1909

THE FOREGOING EXPRESSES ALL OF TOYOTOMI'S OBLIGATIONS AND LIABILITIES WITH RESPECT TO THE QUALITY OF PRODUCT FURNISHED BY IT. ALL OTHER WARRANTIES, EXPRESS OR IMPLIED, INCLUDING THE WARRANTIES OF MERCHANTABILITY OR FITNESS FOR A PARTICULAR PURPOSE ARE DISCLAIMED. TOYOTOMI SHALL NOT BE LIABLE FOR THE LOSS OF USE OF THE PRODUCT, INCONVENIENCE, LOSS OR ANY OTHER DAMAGES, DIRECT OR CONSEQUENTIAL ARISING OUT OF THE USE OF, OR INABILITY TO USE THE PRODUCT OR DAMAGES RESULTING FROM OR ATTRIBUTABLE TO DEFECTS IN THE PRODUCT.

No one other than TOYOTOMI has authority to extend or modify the terms of this Limited Warranty in any manner whatsoever.

Some states do not allow the exclusion or limitation of incidental or consequential damages or limitations on how long an implied warranty lasts, so these limitations or exclusions may not apply to you. This Limited Warranty gives you specific legal rights and you may also have other rights which vary from state to state.



TOYOTOMI U.S.A., INC.
604 Federal Road, Brookfield, CT 06804